

# Hydraulic System Overview

## Rig-Integrated Equipment

Two high-capacity 3-stage telescopic hydraulic cylinders from the original rig design, dedicated to mast raising and lowering.

Hydraulic Power Unit (HPU) rated at 60 kW, capable of delivering 35 GPM at 3000 psi, as per original rig specifications

## System Components

Rotary Gear Flow Divider for precise fluid distribution, ensuring synchronized cylinder movement.

Directional Control Valves (DCVs) and Counterbalance Valves (CBVs) for smooth, controlled, and safe operation.

High-pressure rated hoses compliant with ISO VG-68 hydraulic oil standards.

Flow meters for real-time monitoring of hydraulic performance.

# MAST SYNCHRONIZATION SYSTEM

## Hydraulic and Electrical Integration

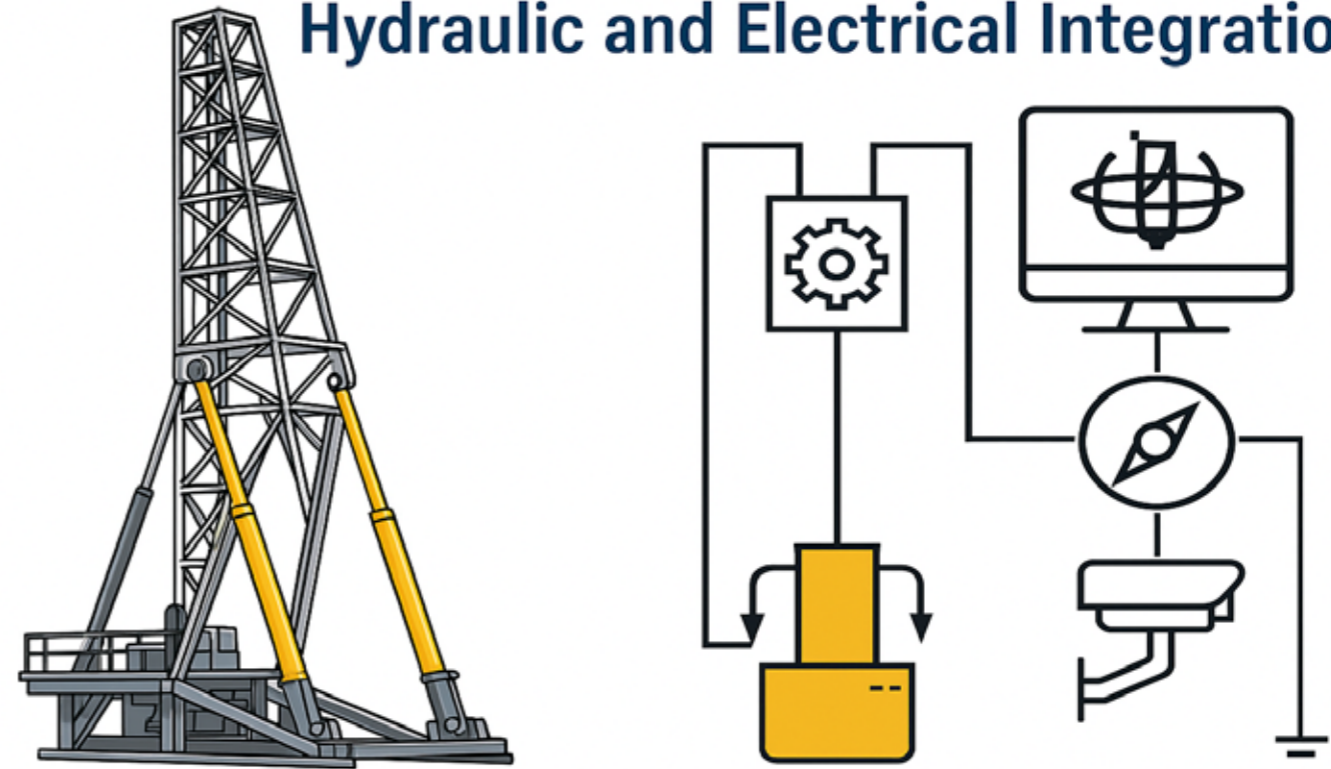

## Introduction

### Purpose:

To provide a seamless, safe, and efficient method for raising and lowering rig masts.

Innovation: Integration of a precision hydraulic cost saving products with advanced electrical monitoring.

### Benefits:

Enhanced operational safety, minimized downtime, and comprehensive event documentation.

The system plays a critical role in incident investigations by providing a complete, timestamped recording of each mast raising and lowering operation, enabling accurate root cause analysis of any accident or malfunction.

Additionally, it offers early detection of potential hydraulic cylinder issues, such as reduced performance or the onset of internal leakage, allowing for timely maintenance before a major failure occurs.

# Mast Cylinder Specifications

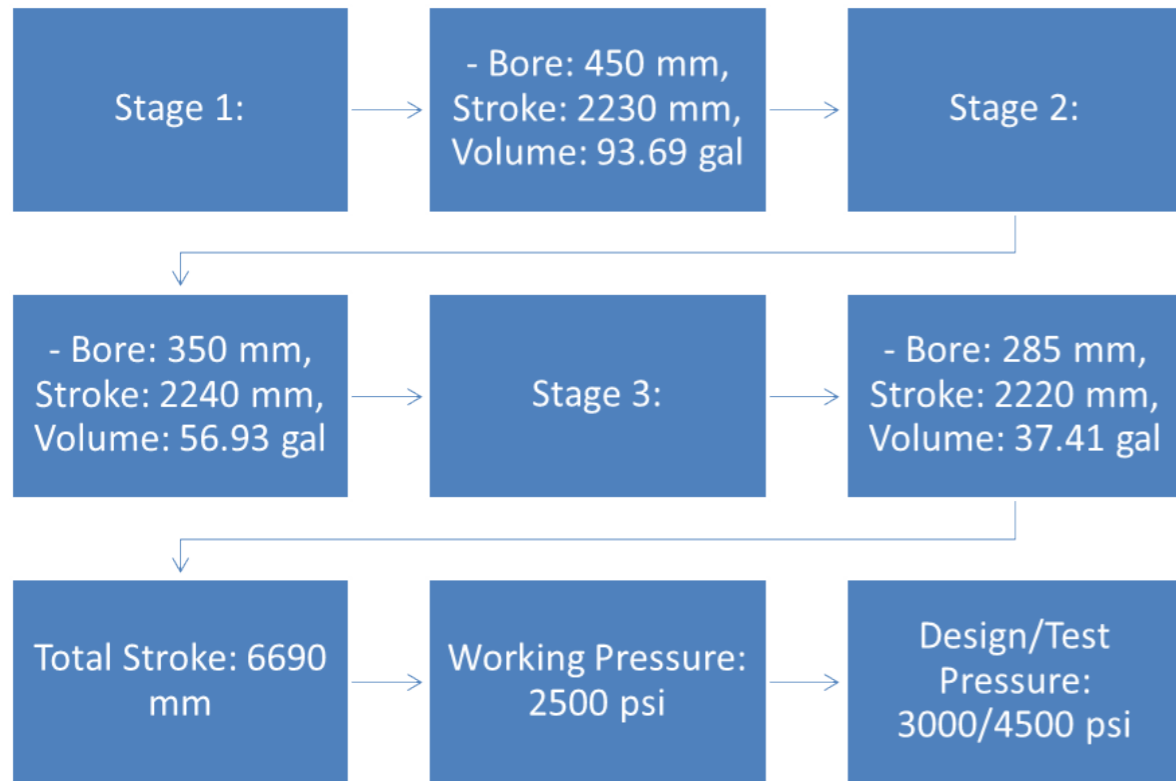

# Flow Rate and Extension Speed per Stage

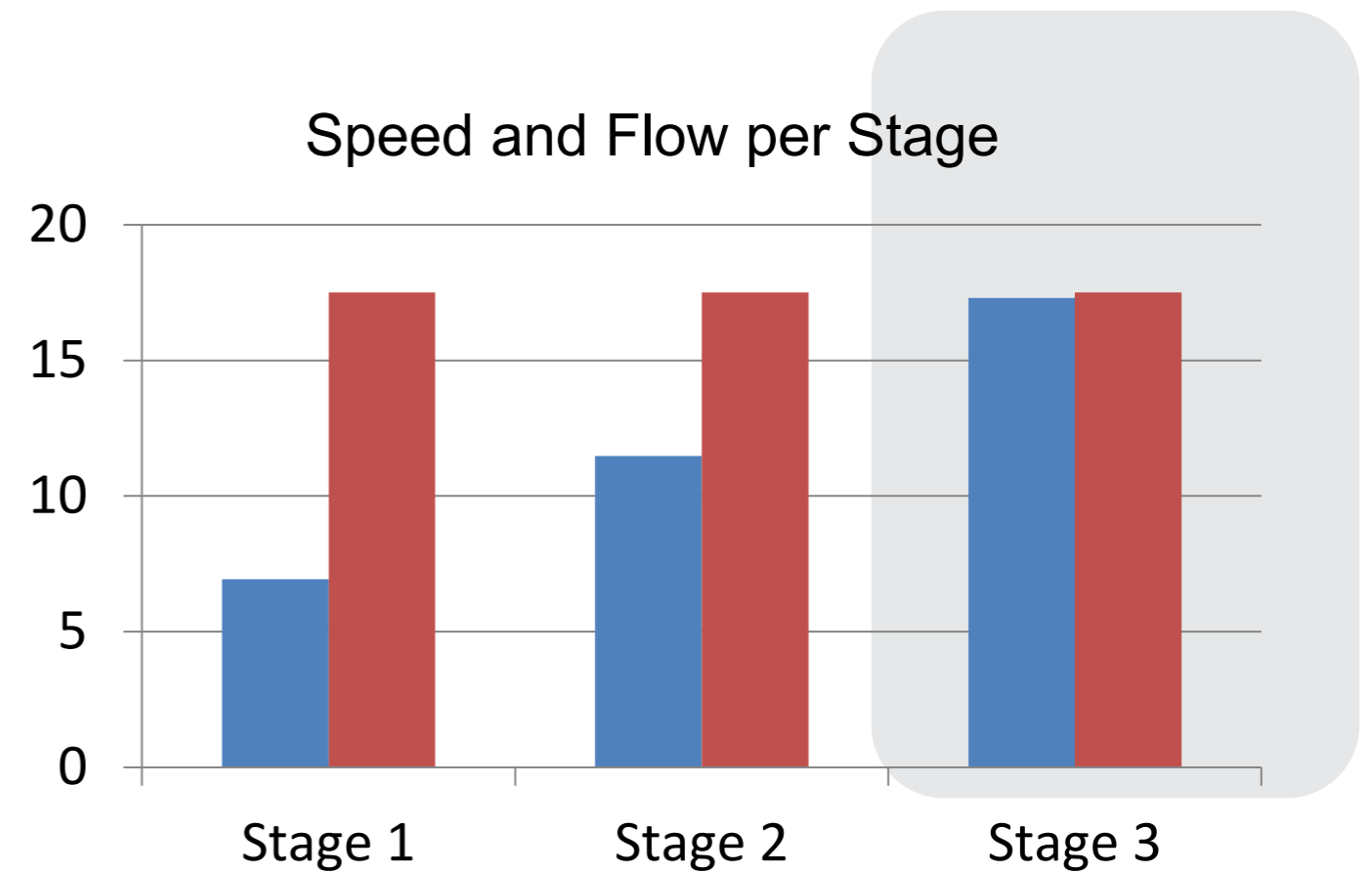

## Safety Assurance

- All original rig safety devices ( HPU pump safety relief valve, cylinder counterbalance ) are fully retained, ensuring compliance with OEM specifications and maintaining the highest level of operational safety.
- Our system is engineered to function as a full redundancy solution, utilizing the rig's original safety tools and protocols to guarantee safe, uninterrupted operation in the event of a primary system failure.



## Synchronization Principle

A rotary gear flow divider ensures equal flow to each cylinder. Mechanically linked gears rotate at the same speed, delivering equal displacement. This maintains synchronized extension and retraction of the cylinders.

## Advantages of Synchronization

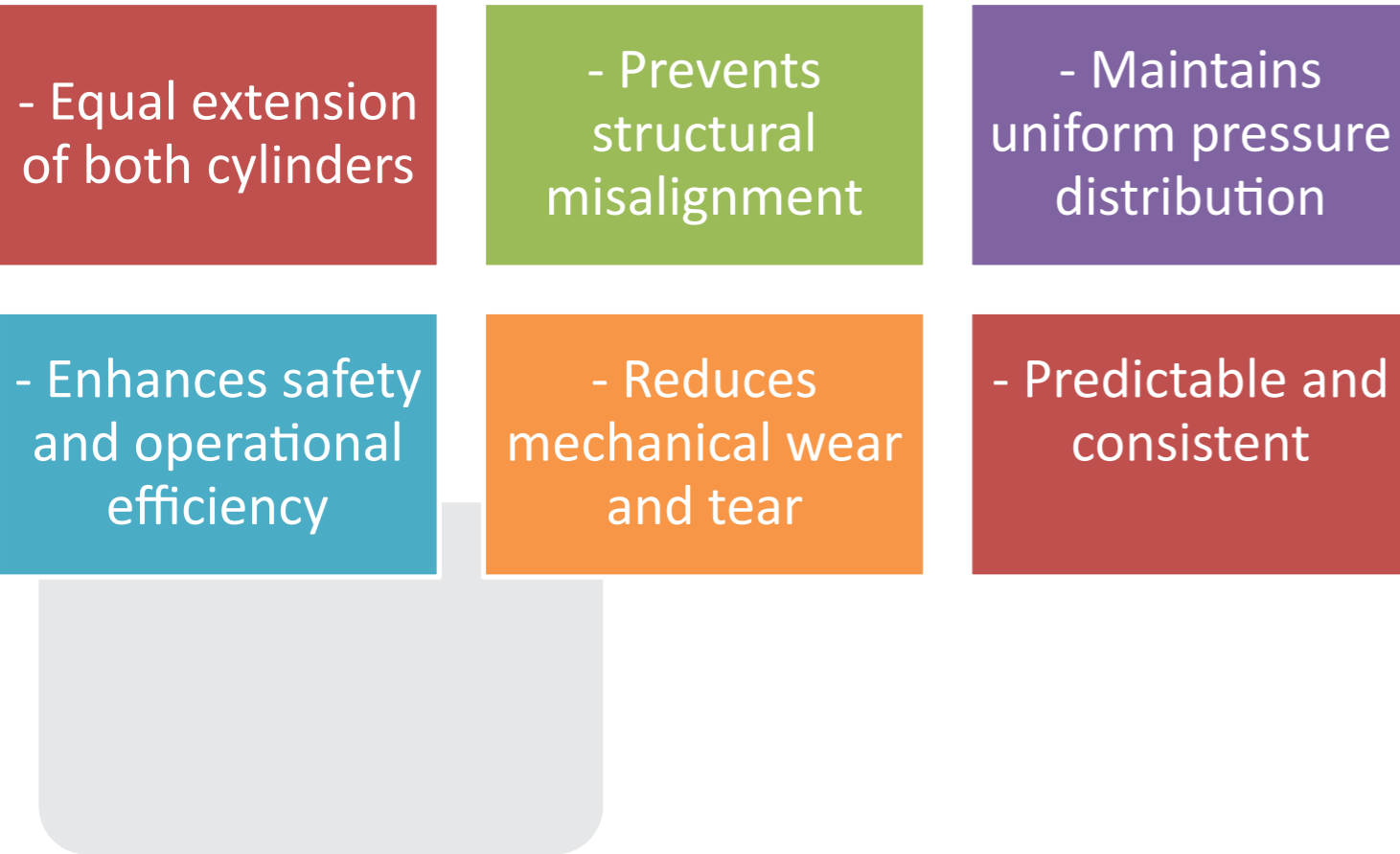

## Maintenance & Safety Notes



- ✓ - Bleed air before each operation
- ✓ - Inspect hoses, seals, and rods biweekly
- ✓ - Annual NDT and pressure testing
- ✓ - 3-year overhaul at certified workshop
- ✓ - Follow safety protocols during maintenance

### Hydraulic Components Overview

- Flow Divider: Ensures equal flow to both cylinders
- 6-Position Valve Selector: Directs flow to selected circuits
- 4/3 Directional Control Valve: Controls extend/retract of cylinders
- Flow Meters (3x): Monitor flow to each cylinder and return
- Hoses: High-pressure rated, ISO VG-68 compatible

### Hydraulic Flow Path

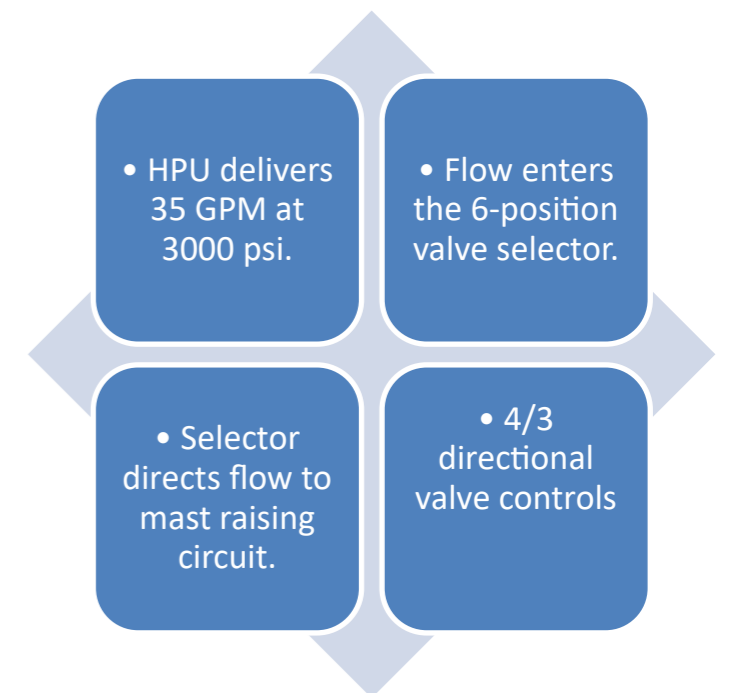

# Synchronization Mechanism



- Flow divider splits flow equally to both cylinders.



- Each path feeds one 3-stage telescopic cylinder.



- Flow meters monitor flow to each cylinder and return.



- Ensures synchronized extension regardless of load imbalance.

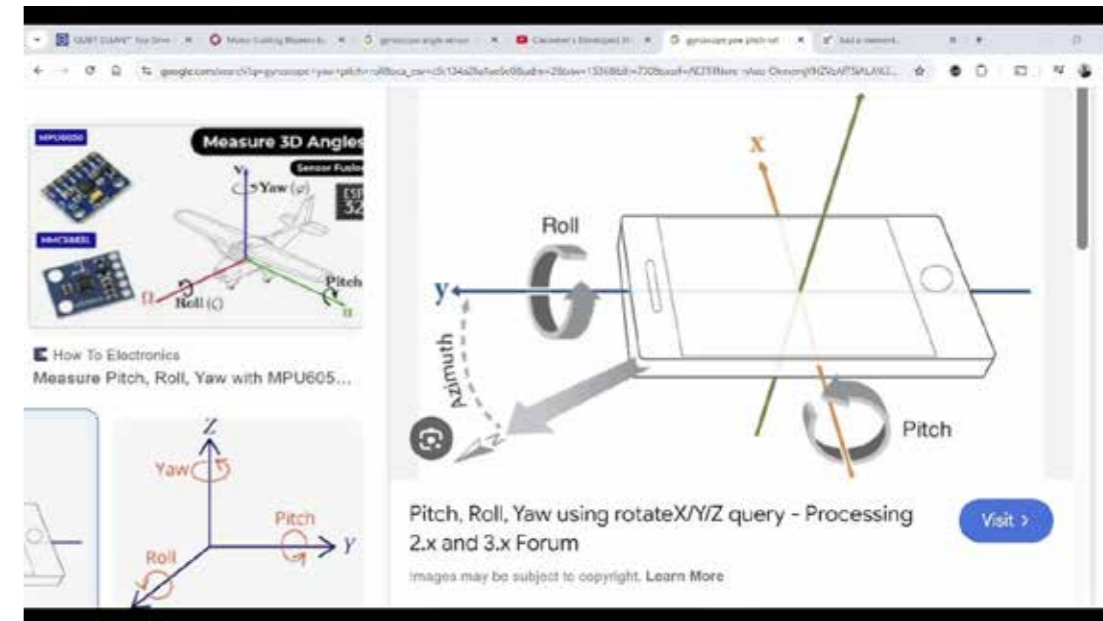

## Electrical & Software System

Dual high-precision gyroscope sensors monitor mast angles continuously on both sides.

Real-time processing detects any deviation between sides, triggering alarms as needed.

Alarm system hierarchy: Yellow (early warning), Red (critical action required).

Data logging of every raising/lowering cycle for performance analysis and incident investigation.

RTSP camera feed integration for live video display with on-screen deviation level indicator.

Customizable user interface showing mast status, sensor readings, and operational history.

Calibration tools to set reference angles before operation.

# Key Advantages of the Integrated System



Superior safety: Hydraulic precision combined with electrical real-time monitoring.

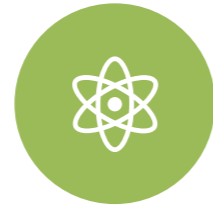

Innovative fusion of mechanical synchronization and smart software analytics.



Detailed event recording enables root cause analysis in case of incidents.



Enhanced productivity through reduced downtime and predictive maintenance.



User-

# Our Cost Saving Products

The integrated mast raising and lowering system delivers unmatched reliability and safety. Combining robust hydraulic engineering with intelligent monitoring ensures optimal performance. Ideal for modern drilling rigs aiming to enhance safety, efficiency, and operational transparency. Deliverables include Full operation manual, troubleshooting guide, animated hydraulic circuit video.

## Cost Saving PRODUCTS

1. TAN DELTA AND RRR FILTRATION
2. ALPHA SYSTEM FOR DIESEL AND GASENGINES
3. POWER FACTOR CORRECTION UNIT FOR DC RIGS
4. HYBRID ENERGY TECHNOLOGY (HET)



## What you see: TDN variation

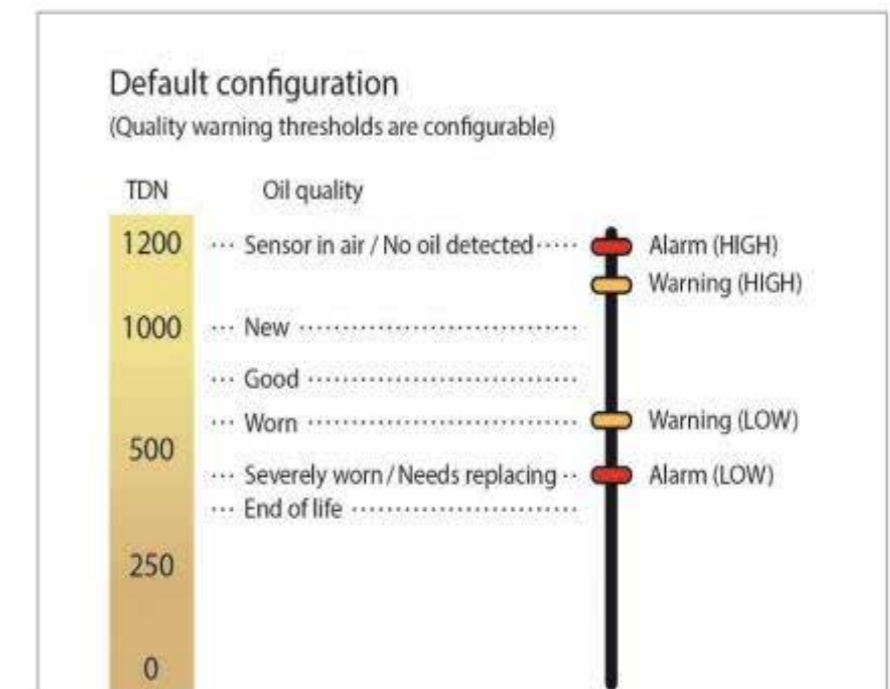

### Tan Delta technology

- To configure the Tan Delta OQSx sensor, oil profiling is done to correlate TDN with the change in oil parameters
- Such correlated data base for 583 oil types is provided by Tan Delta
- Unlike other oil quality sensors, Tan Delta employs Full Scale Holistic (F-SH) oil quality data for each specific oil, by incorporating all the below mentioned parameters in TDN:

- |                                    |                                     |
|------------------------------------|-------------------------------------|
| 1. TAN changes (Total acid number) | 6. Fluids or chemical contamination |
| 2. TBN changes (Total base number) | 7. Viscosity changes                |
| 3. Additive depletion              | 8. Incorrect oil changes            |
| 4. Particulate contamination       | 9. Temperature changes              |
| 5. Water ingress                   |                                     |

# RRR filtration and TDN system

OQMS technology consists of two main pillars:

1. Micro filtration system (RRR)
2. Real-time oil condition monitoring system (Tan Delta)



## TAN DELTA AND RRR FILTRATION

- Tan Delta is a global leader in real-time oil condition monitoring products and solutions.
- Tan Delta employs oil quality sensors (OQSx) to detect oil condition in real-time using patented technology.
- Principle of operation:
  1. Tan Delta sensor generates an electric field within the oil
  2. Ratio of capacitance and conductance of oil is calculated by the sensor
  3. This ratio is compared with the Tan Delta oil database and a TDN (Tan Delta Number) is generated
- TDN is a measure of exact oil quality and ranges from 0 to 1200 (higher the better)

## RRR MICRO FILTRATION

•RRR is an offline oil filtration system that employs:

1. Bypass loop (kidney loop) to increase the effectiveness of filtration
  2. Depth filtration technology to capture maximum number of contaminants
- Due to low pressure and constant flow within the cellulose filter (patented), performance of the system is highly efficient (more than 99.75 % of all contaminants greater than 3 $\mu$  are captured)

## What you see: TDN variation

TDN reflects the overall health of the oil on a scale of 1200-0. Higher the number, better is the oil quality.

- 1200-Sensor in air
- 1000-Fresh sealed oil
- 1000 to 600-Good oil
- 600 to 300-Worn, replacement needed
- <300-Debris of the oil shall cause

Hampering to the engine (Immediate oil Change is required)

Along with TDN, Tan Delta display provides rate of Change of oil quality (ROC) with time and oil temperature.

# Data monitoring options

**Tan Delta provides the below-mentioned oil quality data monitoring options:**

- Oil Quality Display Express (OQDe)
- Oil Quality Display Professional (OQDp)
- Monitoring on PC or Laptop
- Wireless remote monitoring through Cloud
- Analog (4-20 mA) to a PLC
- MODbus(RS485) and CANbus

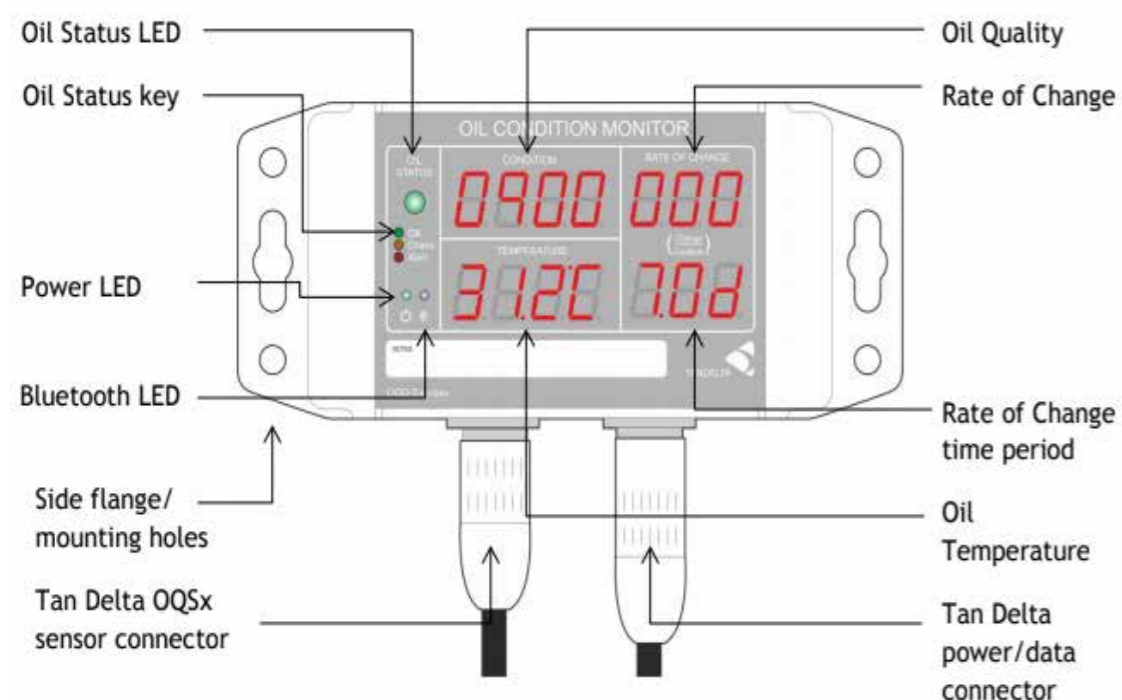

# Oil analysis results post RRR installation

Sl. No.	Oil Health Parameters	Comparison		
1	Oil Running Hours	1540 hrs	956 hrs	440 hrs
2	Status	Ok to use	Ok to use	Ok to use
3	Date Sampled	17/5/2020	06/04/2020	07/03/2020
4	Date Received	30/5/2020	12/04/2020	17/03/2020
5	Viscosity 40 C cSt	91.95	92.98	96.75
6	Viscosity 100 C cSt	12.81	12.88	13.47
7	Viscosity Index	136	136	139
8	Closed Flash Point C	> 200	> 200	> 200
9	Total Insolubles %	0.08	0.07	0.1
10	Total Base Number	8.82	9.04	10
11	Water Content %	390 ppm	388 ppm	< 0.05
31	Sodium ppm	1	1	1
32	>4µm particles/ml	139215	205286	-
33	>6µm particles/ml	9062	23213	-
34	>14µm particles/ml	57	888	-

In addition to the above direct savings achieved by using OQMS, further savings (around 30% ) can be achieved on the life cycle cost of the engine by using our engine diagnostic solution . This is an early warning non-invasive system & by using two MPU, we can help you to identify the cylinder specific engine condition from outside. This will help you to eliminate breakdowns, post-pone overhauls (with complete peace of mind) & at extended running hours do the bare minimum changes required rather than going for a conventional overhauling list.

## Cost Benefit Analysis

### Direct Savings

- Oil tank capacity -400 liters of engine lube oil
- Estimated running hours during pilot project -2000 hours
- Pilot project tenure -4 months
- Existing oil replacement interval -1000 hours
- Landed cost of oil on board -\$2.2/liter
- OQMS has helped to extend oil life to 2000 hours
- OQMS has helped to save cost of one oil replacement over a period of 4 months
- Savings on lube oil expenses over a period of 4 months by using OQMS -400 \* 2.2 = \$880
- Average engine running hours per year -6000 hours
- Currently lube oil is being replaced six times a year
- OQMS helps to extend oil life by 2X times
- In a year cost of three oil replacements can be saved using OQMS
- Estimated savings on lube oil expenses in 1 year (per engine) by using OQMS -880 \*3 = \$2,640
- Estimated savings on lube oil expenses in 1 year (per rig with 4 engines) by using OQMS -880 \*3 \*4 = \$10,560

## ALPHA SYSTEM FOR DIESEL AND GAS ENGINES

- Principle – Measurement of Torsional Vibration and analysis of its variation through statistical and mathematical computation
- To derive component specific and overall engine health indicators.
  - MPU measures the Torsional vibration
  - TDC Sensor references the cylinders

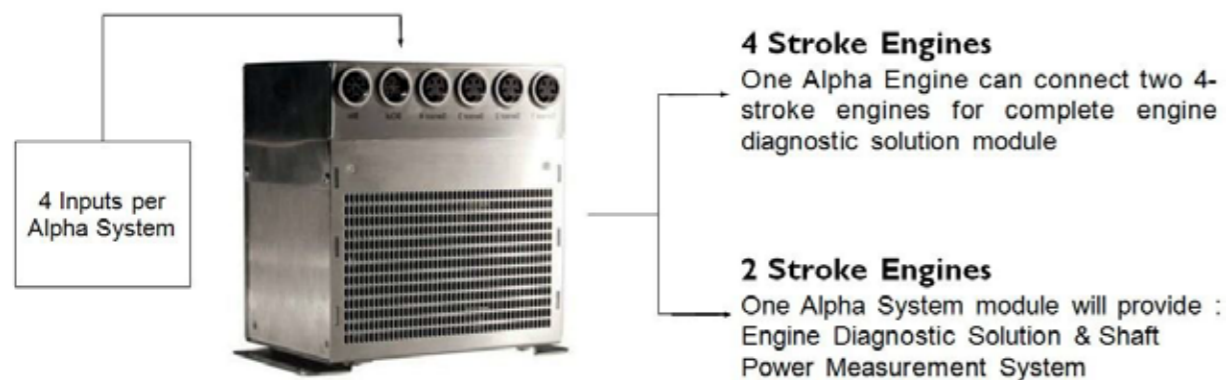

### The Technology

Principle-Measurement of Torsional Vibration and analysis of its variation through statistical and mathematical computation to derive component specific and overall engine health indicators.

1st MPU measures the Torsional Vibration at Engine Crankshaft

2nd MPU at TDC references the cylinders

3rd MPU measures Torsional Vibration at Alternator

### alpha GENSET:

Module consists of :

- Diesel Engine Analysis
- Alternator Analysis

### Installation :

- Two MPUs to be installed on the Engine
- One MPU to be installed on the Alternator
- Current Monitoring Sensor on switchboard

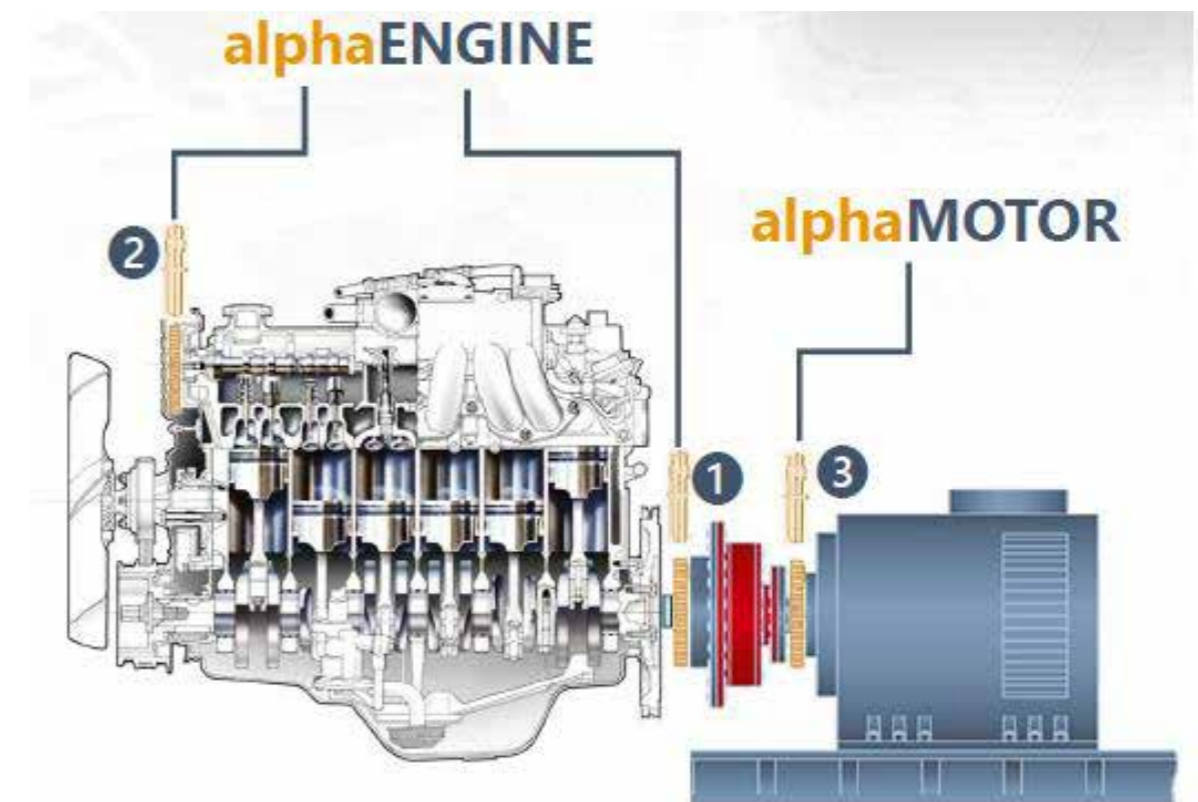

# Diesel Engine Indicators

## OVERALL INDICATORS

- Mechanical Health
- Operating Condition
- Mechanical Stresses
- Stresses on foundation
- Torsional Angle
- Power in KW

Date (UTC)	Name [4-stroke engine]	Speed ± Delta	Synchronization = TDC
07.07.2018 02:58:22	Genset1CutOut3	899 ± 0.4	

### Mechanical Health



### Operating Condition



### Mechanical Stresses



### Mounts

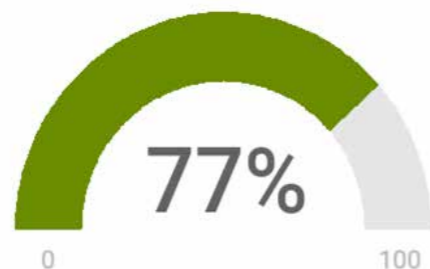

### Torsional Angle

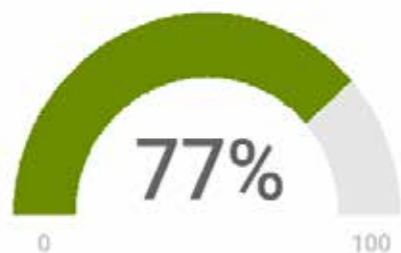





























### Power



# Diesel Engine Indicators

## CYLINDER SPECIFIC HEALTH INDICATORS

	General in %	1	4	2	6	3	5
Compression							
Injection Timing							
Injection Condition							
Bearing							

## COST SAVING

- 12 Month Rental Contract
- We have offered here a 12-month rental model considering 10 engines in two close rigs
- Per month rental price -2300 USD + taxes (if any)
- Installation & Commissioning charges -1800 USD, one time + taxes (if any)
- Inclusions in above price;
- Alpha diagnostic tool & necessary hardware for monitoring the engines
- We have considered here 100 meters of cable. If any additional, same will be chargeable as per actual

## Diesel Engine Indicators

### Benefits

- Reduction in Maintenance Cost
- Through this solution, ADNOC will be able to identify the cylinder specific health of the engine & based on the prediction, they can do the bare minimum overhaul required rather than going for a conventional overhaul. From our experience, we have seen that it helps to save at least 30% to 40% on their overhauls
- In addition to the above the downtime on overhaul is also saved
- This is an early warning solution & hence this will help you to identify any upcoming failure well in advance. This will help to reduce inventory carrying cost as now with the prediction from our system, further maintenance can be planned accordingly
- Enhanced Reliability
- Completely eliminates chances of any breakdown

## POWER FACTOR CORRECTION AND FUEL CONSUMPTION REDUCTION

- When connected to DC rig and By setting PF value to 0.90 then the efficiency will be increased and rig will run like an AC rig with VFD Drives with much less Fuel consumption.
- The amount of Saving and other benefits will depend on how low the power factor goes down and the time it remains on low PF.

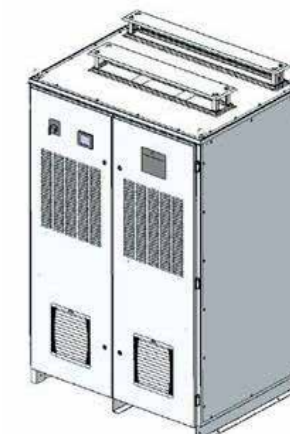

### Power Factor Correction and Fuel Consumption Reduction

Efficient energy management is critical to reducing operational costs and ensuring sustainable performance. Power Factor Correction (PFC) plays a vital role in improving the efficiency of electrical systems by reducing reactive power demand, stabilizing voltage levels, and lowering electrical losses. By optimizing the power factor, industries can significantly decrease their utility costs, extend equipment lifespan, and enhance overall system reliability.

### Fuel Consumption Comparison of 1200 KW Load when running on DC Rig with 0.55 PF VS AC Rig with 0.8 PF

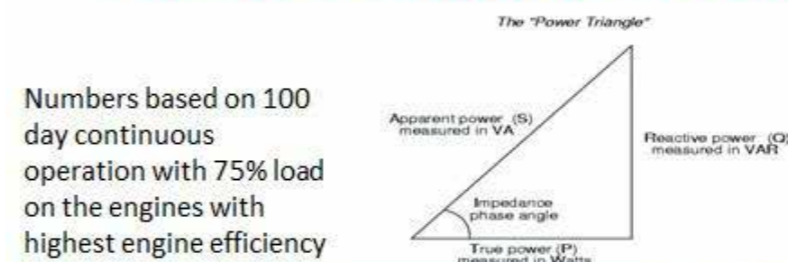

55% PF	80% PF
2100 KVA	1500 KVA
5010 MVAH/yr	3600 MVAH/yr
1,027,000 L /yr	730,000 L/yr
930,000 US\$	650,000 US\$



# PF Correction For DC Rigs Big Window for savings

# AHF Filtration for AC / DC Rigs

Dedicated AHF for DC or AC Rigs

Design can be customized based on Rig specific Harmonic Survey

Solution can be a full size 20 feet container or a panel placed inside power house.

Solution can be tuned and customized to select the anti-harmonics number to match current loads harmonics.

Auto function to match and cancel any harmonics up to 51st to bring down THD for (voltage, current) to comply with IEEE 519 standard.

Solution can be designed to mitigate HARMONICS OF 600 vac Main AC BUS or 480 VAC or even for 208VAC lighting and control bus and also for rig camp if fed from rig power.

Table4 Apparent Genset total currents Current VS PF & KW Matrix

PF / KW	300	400	500	600	700	800	900	1000	1100	1200	1300	1400	1500	1600	1700	1800	1900	2000	2100	2200	2300	2400	2500	2600	2700	2800	2900	3000
0.3	963	1285	1606	1927	2248	2569	2890	3211	3532	3854	4175	4496	4817	5138	5459	5780	6101	6423	6744	7065	7386	7707	8028	8349	8671	8992	9313	9634
0.35	826	1101	1376	1652	1927	2202	2477	2753	3028	3303	3578	3854	4129	4404	4679	4955	5230	5505	5780	6056	6331	6606	6881	7157	7432	7707	7982	8258
0.4	723	963	1204	1445	1686	1927	2168	2408	2649	2890	3131	3372	3613	3854	4094	4335	4576	4817	5058	5299	5539	5780	6021	6262	6503	6744	6985	7225
0.45	642	856	1070	1285	1499	1713	1927	2141	2355	2569	2783	2997	3211	3425	3639	3854	4068	4282	4496	4710	4924	5138	5352	5566	5780	5994	6209	6423
0.5	570	771	963	1156	1349	1541	1734	1927	2119	2312	2505	2697	2890	3082	3276	3468	3661	3854	4046	4239	4432	4624	4817	5010	5203	5395	5588	5780
0.55	525	701	876	1051	1226	1401	1576	1752	1927	2102	2277	2452	2627	2803	2978	3153	3328	3503	3678	3854	4029	4204	4379	4554	4729	4904	5079	5255
0.6	482	642	803	963	1124	1285	1445	1606	1766	1927	2087	2248	2408	2569	2730	2890	3051	3211	3372	3532	3693	3854	4014	4175	4335	4496	4656	4817
0.65	445	593	741	889	1037	1186	1334	1482	1630	1779	1927	2075	2223	2371	2520	2668	2816	2964	3112	3261	3409	3557	3705	3854	4002	4150	4298	4446
0.7	413	551	688	826	963	1101	1239	1376	1514	1652	1789	1927	2064	2202	2340	2477	2615	2753	2890	3028	3165	3303	3441	3578	3716	3854	3991	4129
0.75	385	514	642	771	899	1028	1156	1285	1413	1541	1670	1798	1927	2055	2184	2312	2441	2569	2697	2826	2954	3083	3211	3340	3468	3597	3725	3854
0.8	361	482	602	723	843	963	1084	1204	1325	1445	1566	1686	1806	1927	2047	2168	2288	2408	2529	2649	2770	2890	3011	3131	3251	3372	3492	3613
0.85	340	453	567	680	793	907	1020	1133	1247	1360	1473	1587	1700	1813	1927	2040	2153	2267	2380	2493	2607	2720	2834	2947	3060	3174	3287	3400
0.9	321	428	535	642	749	856	963	1070	1177	1285	1392	1499	1606	1713	1820	1927	2034	2141	2248	2355	2462	2569	2676	2783	2890	2997	3104	3211
0.95	304	406	507	608	710	811	913	1014	1116	1217	1318	1420	1521	1623	1724	1825	1927	2028	2130	2231	2332	2434	2535	2637	2738	2839	2941	3042



Our Solution for SVG PF Correction has integrated AHF with it to cancel 5,7, 11,13 Harmonics reducing THDv below 5% We have proven saving of 900 liters per day (20%) We have a proven average saving of 500 engine hours per month reducing service and maintenance cost by a considerable factor

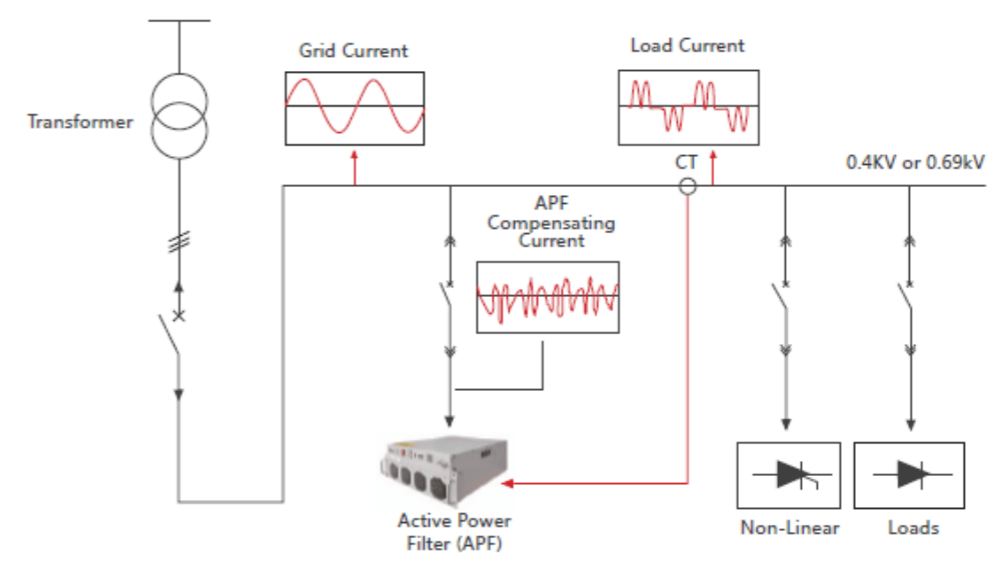

# HYBRID ENERGY TECHNOLOGY (HET)

The new HET Energy Storage Container from Al Nukhba is a very effective fuel saving and cost reduction tool that works with continuous switching cycle for any local diesel power generation system.

Due to the nature of the free energy produced from Draw Works (Hoist), while moving down, HET can catch and store this free energy and reuse it again when Draw works starts moving up; Preventing engines sudden ramping/loading.

Oil Rigs “particularly small size AC drilling rigs and workover rigs”, are the best example where HET could be applied and offers



- Maximum fuel savings
- Reduced engine running hours.
- Reduced engines maintenance cost.
- Reduced initial cost for power control houses

# HET ESS for AC / DC Rigs with KER

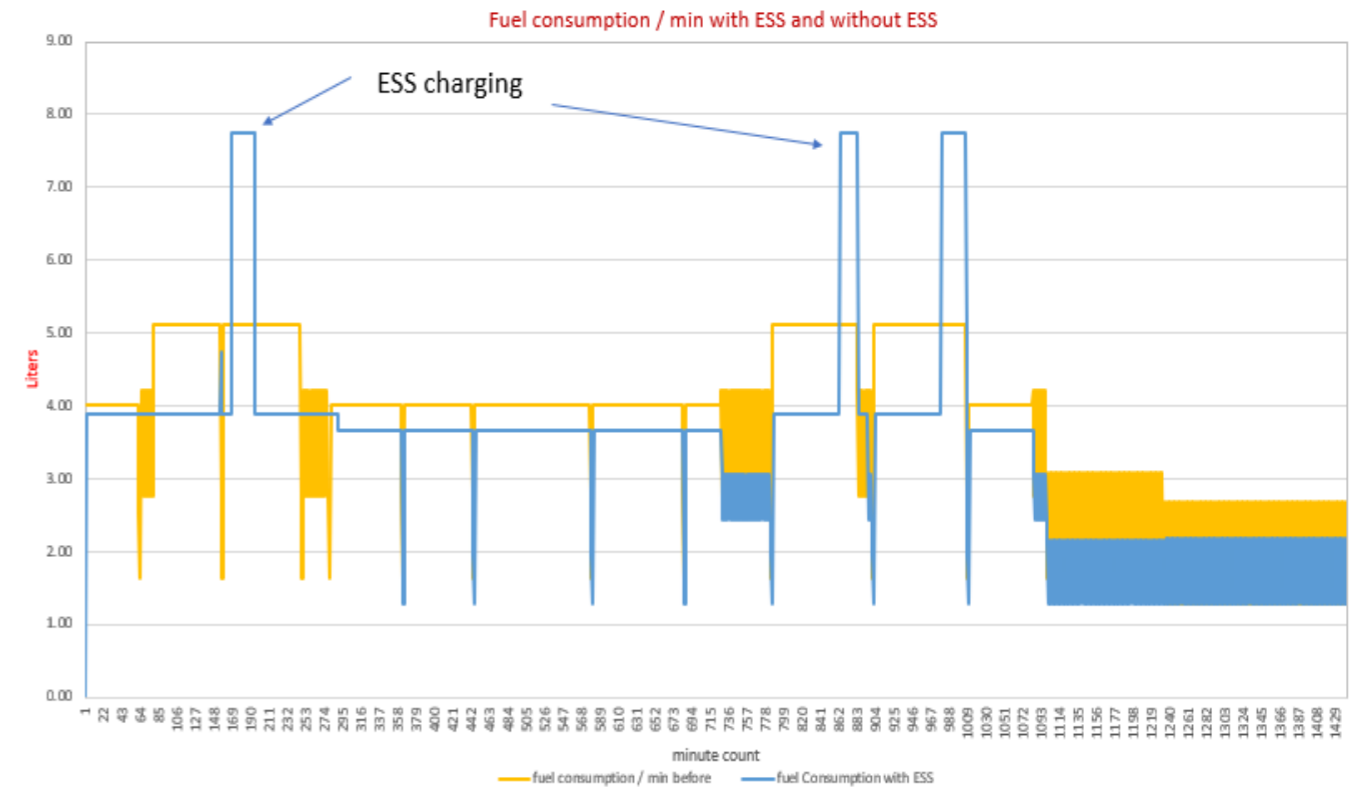

Hybrid Energy Technology is based on ESS ( Energy storage Systems), Basically LION Battery modules monitored by BMS and controlled by Smart EMS ( Energy management System)

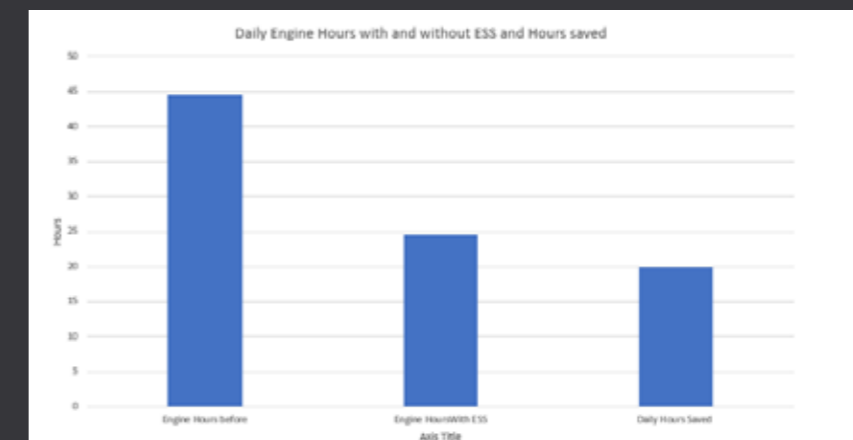

## Benefits of HET ESS for AC / DC Rigs with KER

Uses Draw works Kinetic energy and store it in batteries for AC rigs eliminating bad reputed resistor banks and choppers.

Cancel completely engine ramping (in DC/AC Rigs) for draw works pick up as this sudden load will be covered from ESS.

We think that total cost of owner ship for owning And running ESS container over time is considerably lower than Owning Engine Set.

Also, toward the end of asset life , it seems that engine can be totally disposed while ESS container have relatively much higher Asset life as it only needs battery replacement.

When Comparing NPT and down time , our ESS as a static generators have relatively very low NPT per year when compared to Rotating Genset.

Conclusion :

Owning ESS as Static generator replacing Genset in load varying application like drilling is much more cost effective and can save more than 30% of the running cost.

Item	Value	Unit
Price of 1 liter of Diesel	0.75	US\$
Average cycles before complete replacment	8000.00	Cycles
Price of 370KWH Battery Bank	250000.00	US\$
Cost of Complete Job	140000.00	US\$
Hours for Complete Job	35000.00	Hours
Hours for Top Engine Job	17500.00	Hours
Cost of Top End Job	70000.00	US\$
Cost of Oil Change and other maintenance	1000.00	US\$
Average usage of battery cycle per day	3.00	cycle
Oil Change Every	1000.00	Hours
Rig Move	2.00	Days
Well Program	8.00	Days
Fuel Savings per Day	468.00	Liters
Hours Savings per Day	20.00	Hours
Fuel Saving per well	3744.00	Liters
Fuel Saving Per Year	136656.00	Liters
Hours Savings Per well	160.00	Hours
Hours Savings Per Year	5840.00	Hours
Battery Cylces Used Per well	24.00	Cycles
Battery Cycles Used Per Year	876.00	Cycles
Money Gain From Fuel Per Year	102492.00	US\$
Money Gain From Oil Change	5840.00	US\$
Money Gain From Overhauls and Top Jobs	35040.00	US\$
Money Loss From Battery aging	-27375.00	US\$
<b>Total Money Gain per Year</b>	<b>115997.00</b>	<b>US\$</b>

# Outdoor Cooling System Misting

## Introduction to Outdoor Cooling

Outdoor cooling systems use fog to reduce temperatures for people in covered or open spaces.

A properly designed system can provide dramatic temperature reductions by surrounding all open sides of the area.

## System Layout

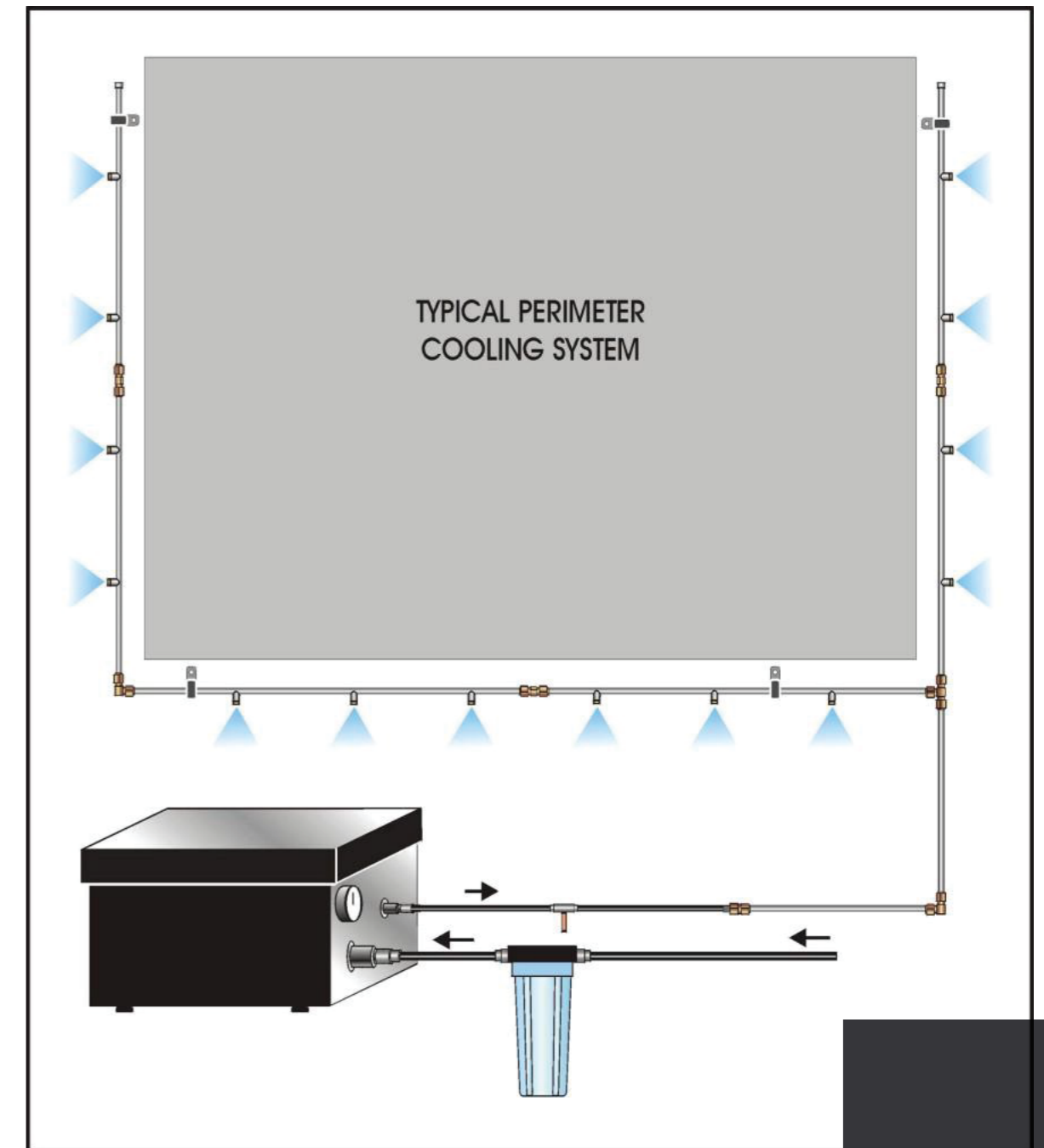

## Clean Air Motor Blower

### System Design Considerations

- Ambient temperature
- Relative humidity
- Covered or open area
- Mounting height of the line
- Structures affecting airflow
- Directional exposure (N, E, S, W)
- Normal wind conditions
- Desired effect from the system



### The Problem

- Motors exposed to sand, dust, and moisture
- Frequent maintenance and downtime
- Reduced service life and reliability



### Our Solution

- Self-cleaning blower system
- Continuous clean airflow
- Protects motors from dust & moisture
- Cuts downtime and costs



### How It Works

Two-stage filtration system  
Removes particles and moisture  
Delivers clean air to the motor

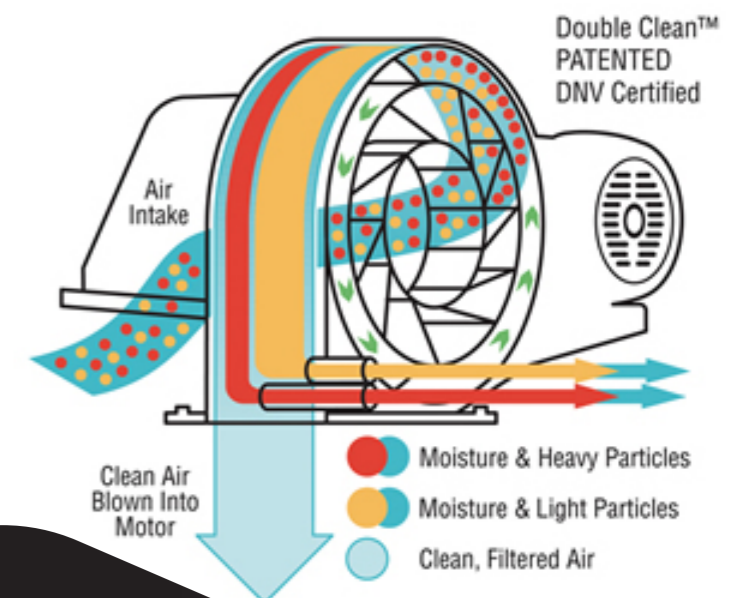

## Key Features & Benefits

- Element-less design → Low maintenance
- 90%+ filtration efficiency
- Durable build for long service life
- TEFC / XP enclosures
- Steel or stainless steel options

## Applications

- Top Drive Motors
- Horizontal traction motors
- DC & AC drilling motors
- Heavy-duty equipment



## Technical Specs

- Horsepower: 5 HP standard
- RPM: 3600 (1800 quiet model available)
- Filtration: Dual-stage system
- Material: Steel / Stainless Steel
- Enclosures: TEFC / XP Cast Iron
- Voltage: Multiple options

## Competitive Advantage

- Standard blowers clog quickly
- CleanAir removes 90%+ particles
- Protects against dust and moisture
- Extends motor life and uptime



BROCHURE  
DESIGN

**Contact Us**

**P :** +968 7709 3791

**E :** [mohamed.mahmoud@interbsnsexpert.om](mailto:mohamed.mahmoud@interbsnsexpert.om)

Al khair , Muscat , Oman